

# INLINE® WALL MOUNT FOR PROJECTOR

max. 16kg



- Stylish Projector Wall Mount
- Projector mount slides along arm for perfect projector placement
- Independent pitch, roll and yaw make it easy to achieve a precise alignment
- Flexible arms and universal fitting make most projectors fit with ease
- Internal cable management keeps cables concealed and organized

- Rated Load: 16kg
- Mounting Range: 180-400mm
- Tilt: +20°~ -20°
- Swivel: +15°~ -15°
- Rotate: +15°~ -15°
- Profile: 225-750mm

Item No:	Color	EAN
23139A	Black	4043718263936

Technical data	
Article height:	5.0 cm
Article length:	61.0 cm
Article width:	121.0 cm
Brand:	InLine®
Cable management:	Yes
GS tested:	No
Load (max.):	16 kg
Monitor arm:	No
Rotatable:	+/-15 °
Safety lock system:	No
Suitable for:	Beamer
Tiltable:	+/-20 °
Type:	Wall Bracket for Beamer
Wall distance:	22.5 - 75 cm

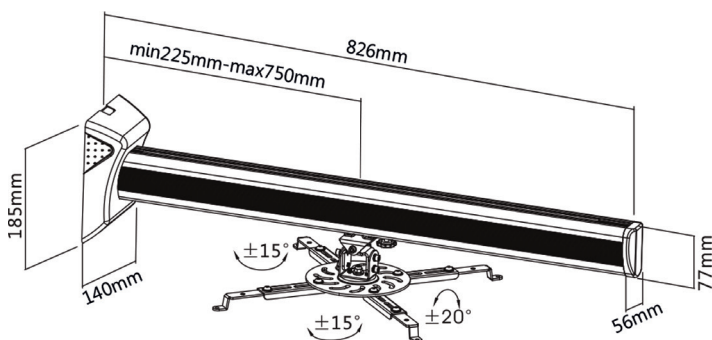

If you have any further questions, please contact [marketing@inline-info.com](mailto:marketing@inline-info.com)

[www.inline-info.com/en/](http://www.inline-info.com/en/)

#### Disclaimer

InLine® is a brand of INTOS ELECTRONIC AG | Siemensstraße 11 | D-35394 Gießen

#### Documentation © 2024 INTOS ELECTRONIC AG

All rights reserved. No part of this document may be reproduced in any form or by any means, electronic, mechanical or chemical, without the prior written permission of the publisher. It is possible that this document may still contain typographical faults or misprints.

However, the information in this document will be checked regularly and corrections will be made in the next edition. We accept no liability for errors of a technical or printing nature and their consequences. All trademarks and industrial property rights are acknowledged. Changes in the sense of technical progress can be made without prior notice. Our products, including packaging, are not toys, they may contain small parts and sharp objects.

Please keep away from children.